

PEKA FORTE

Vollauszug für Holzkonstruktionen
Extension complète pour constructions de caisses en bois
Full-extension runner for wooden cabinets

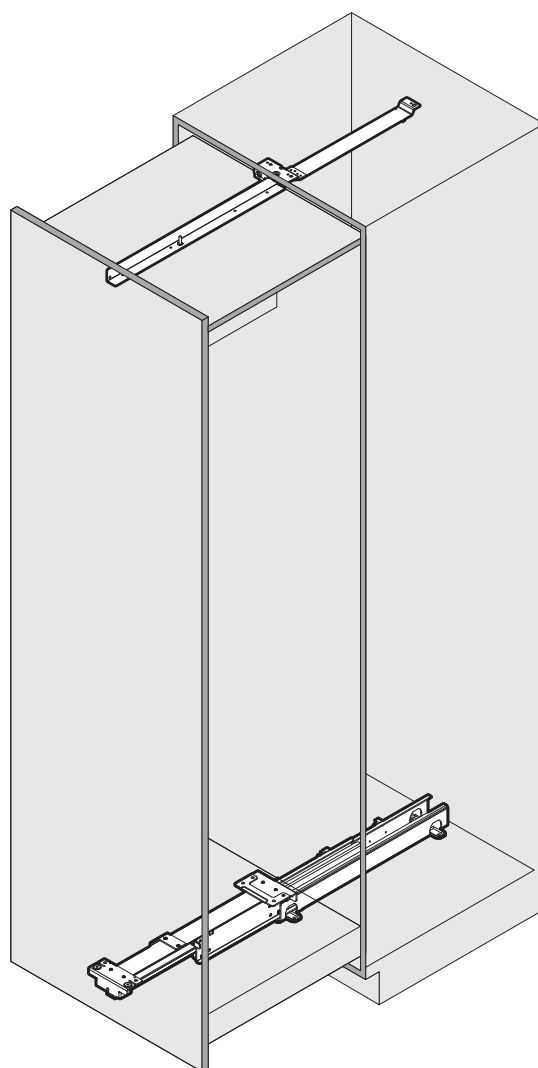

Art.Nr.
380
100.1368.xx
430
100.1369.xx
480
100.1370.xx
530
100.1371.xx
580
100.1372.xx
630
100.1373.xx
680
100.1374.xx
780
100.1375.xx
880
100.1376.xx
980
100.1377.xx
1080
100.1378.xx

VIDEO

+41 41 919 94 04

1x 	1x 	1x 	1x Version A 	1x Version B
--------	--------	--------	------------------	------------------

Option	Option
1x 100.1380.xx	1x 100.1379.xx

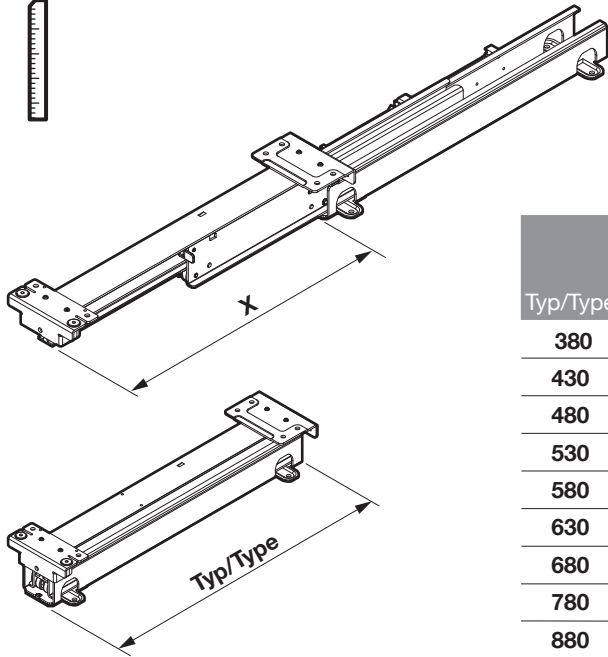
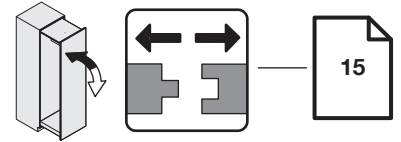
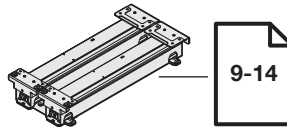
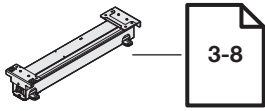

EB	max. 600	max. 800
----	----------	----------

Typ/Type	LT	X	100.1379.xx
380	385	352	✗
430	435	402	✓
480	485	452	
530	535	502	
580	585	552	
630	635	602	
680	685	652	
780	785	752	
880	885	852	
980	985	952	
1080	1085	1052	

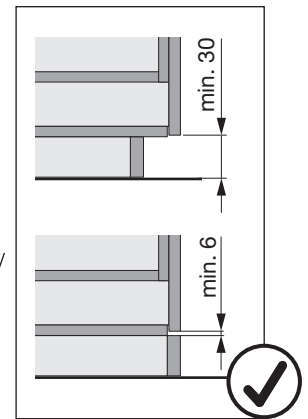
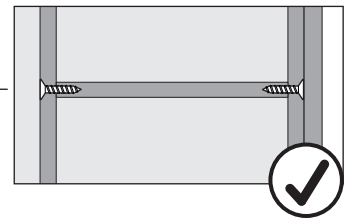
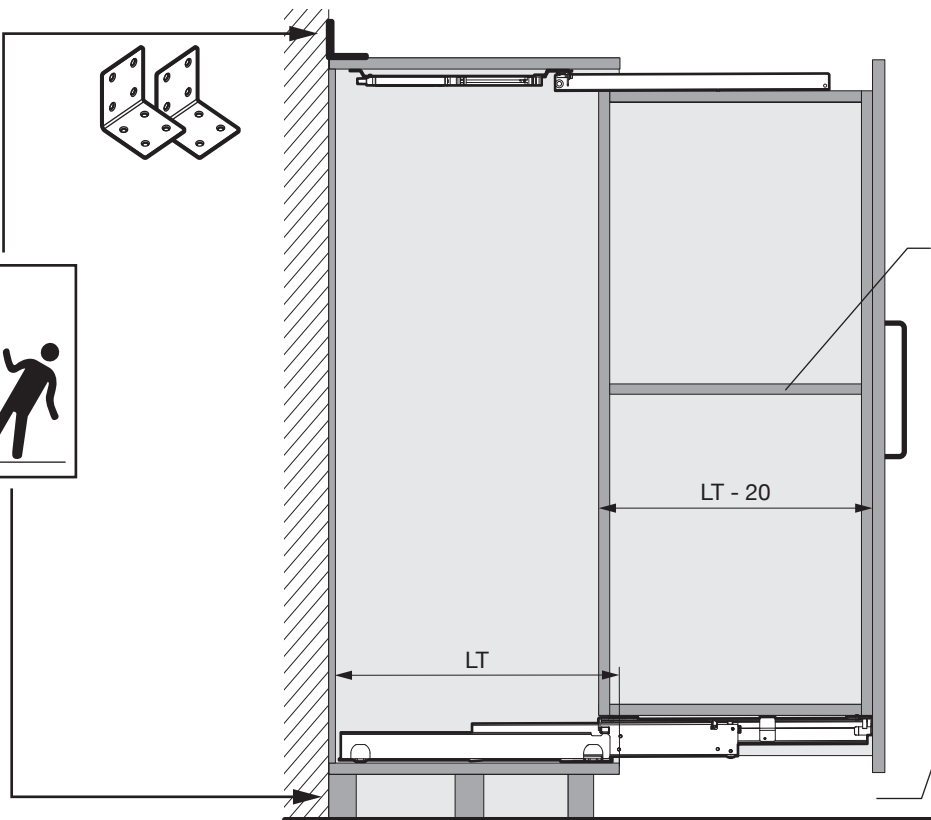
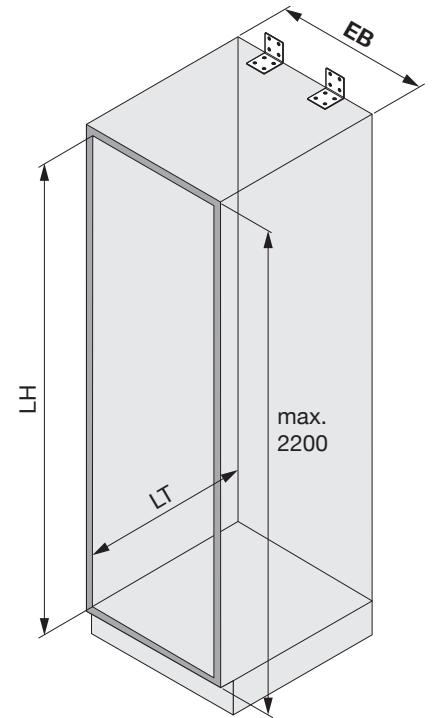

DE Möbelboden und Sockel müssen für 170/340 kg ausreichend verstärkt und tragfähig sein!
FR Le fond de meuble et le socle doivent être suffisamment renforcés et porteurs pour 170 / 340 kg !
EN The furniture base and plinth must be sufficiently reinforced and load-bearing for 170 / 340 kg!

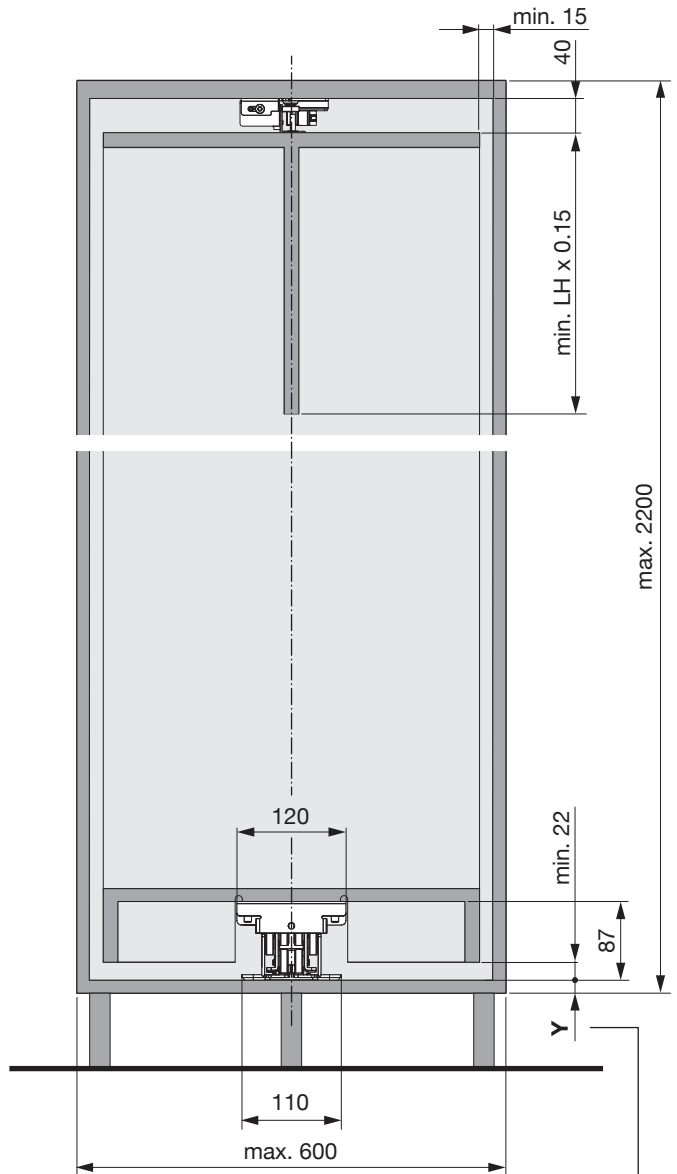
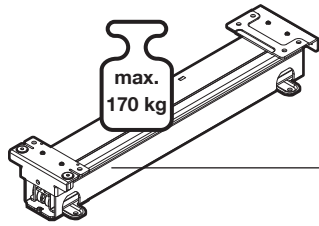
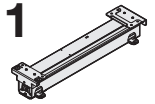

! Rückwand- und Frontausschnitt
 Découpe du panneau arrière et de la façade
 Back wall and front cut-out

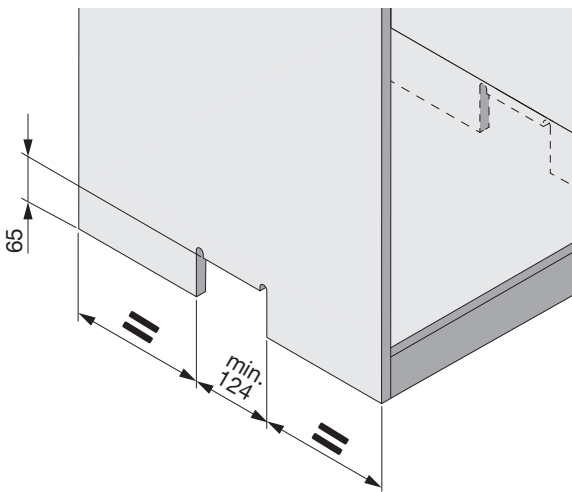

Version A (Standard)
 Y = 16 mm

2x 2x 2x 8x 6x

Version B
 Y = 16-30
 Durchgehend verschraubt
 Vissé traversante
 Bolted through

4x 4x 8x 12x 2x 6x

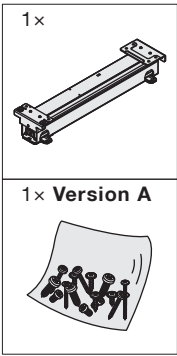
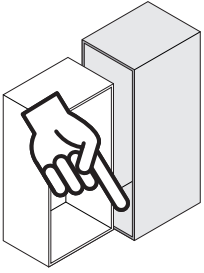
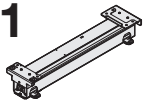
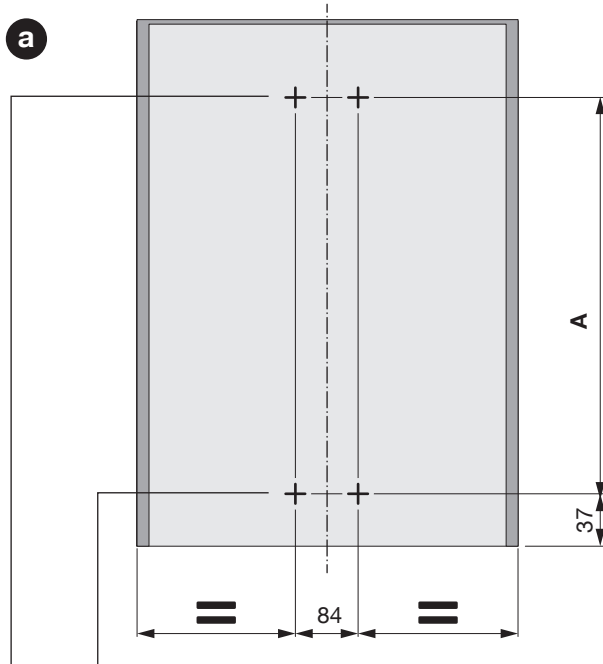

1**1****a**

Typ/Type	A
380	300
430	350
480	400
530	450
580	500
630	550
680	600
780	700
880	800
980	900
1080	1000

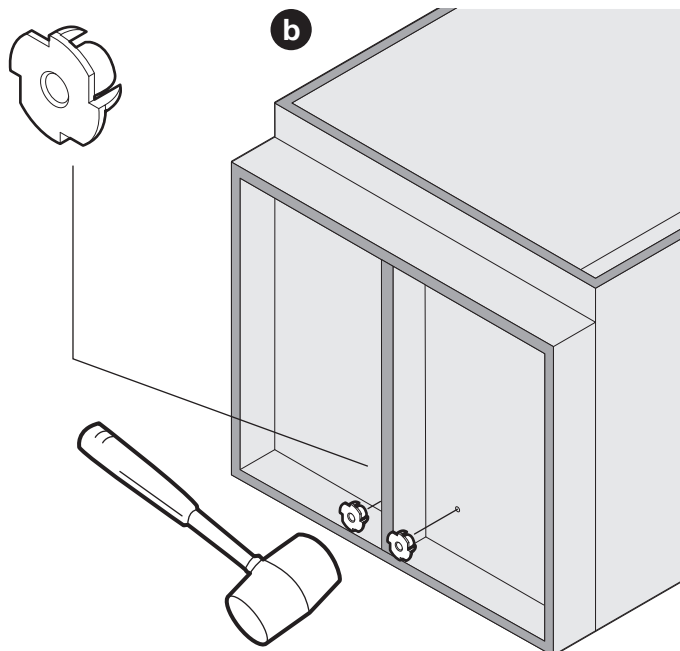
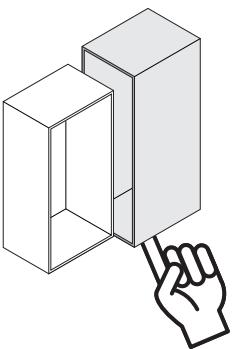
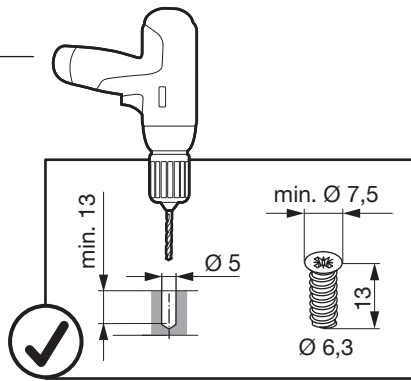
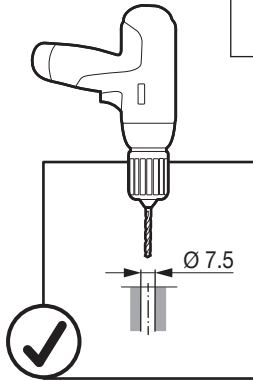

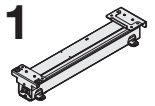

Option Softclose

1x

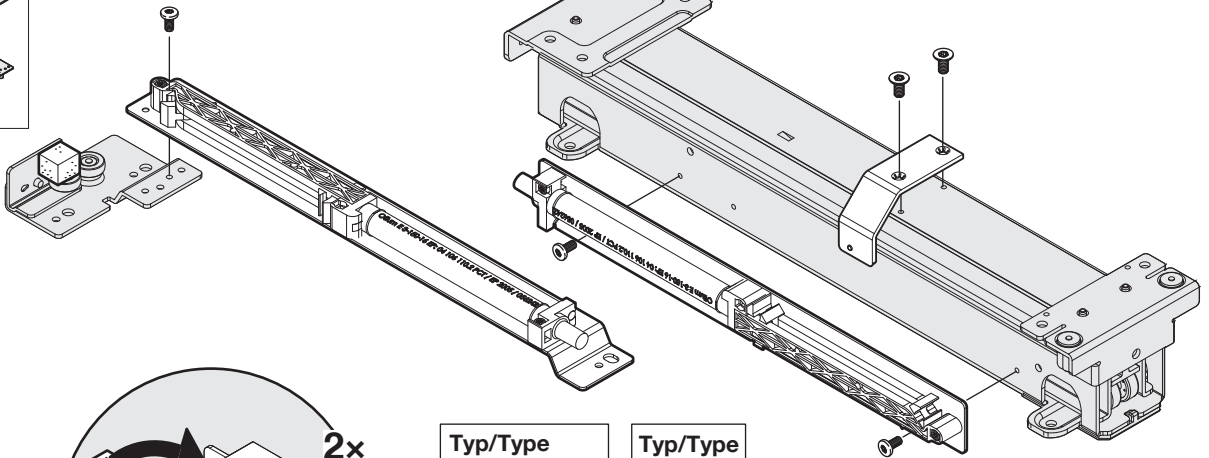
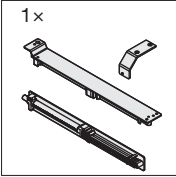

3x



3x



2x



1x

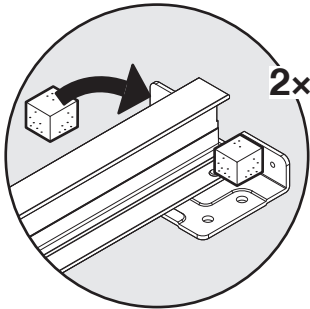

Typ/Type
480, 530, 580,
630, 780
880, 980, 1080

Typ/Type
430



1x

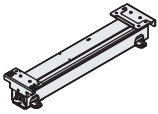

1x Version A

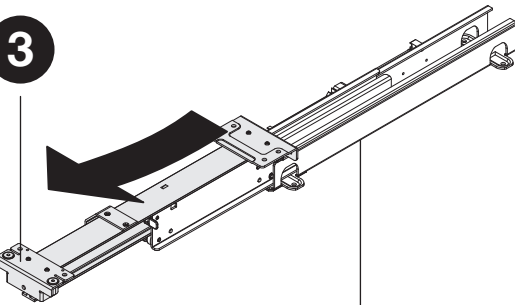

C

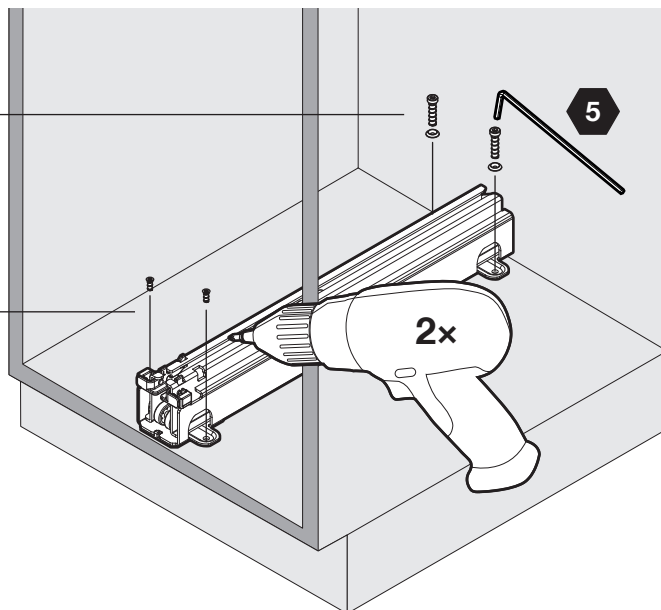
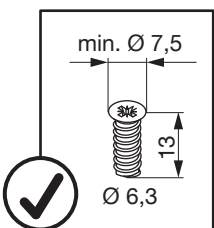
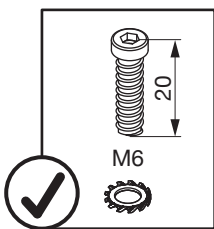

2

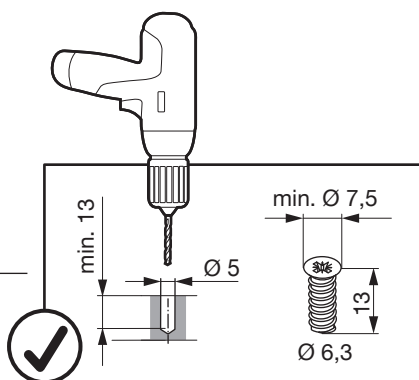
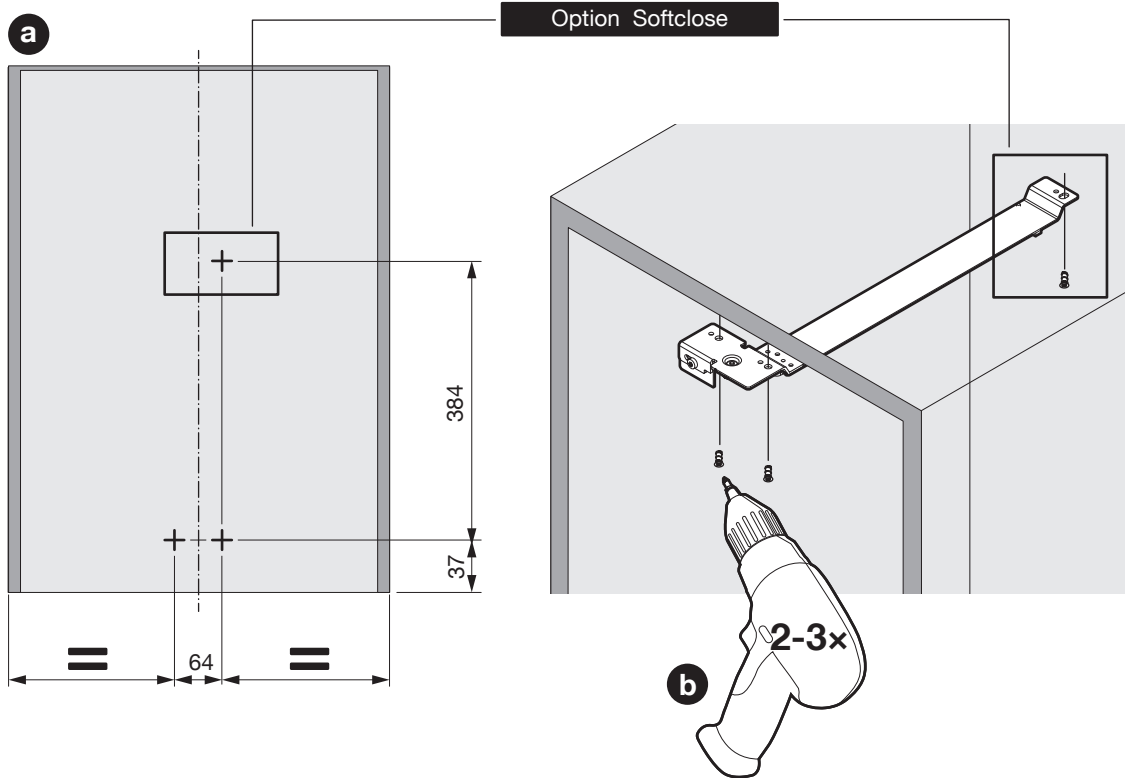
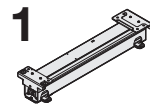
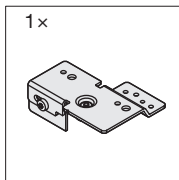
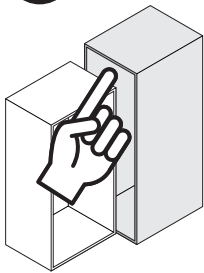

3

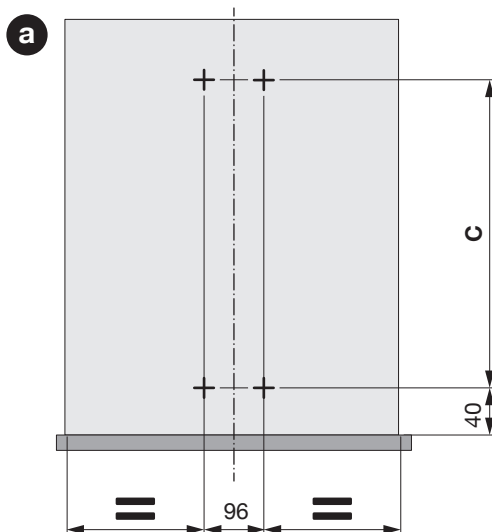
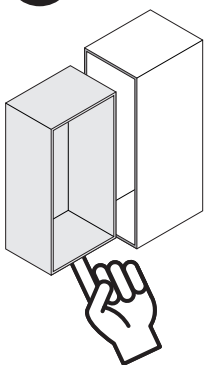

Typ/Type	C
380	280
430	330
480	380
530	430
580	480
630	530
680	580
780	680
880	780
980	880
1080	980

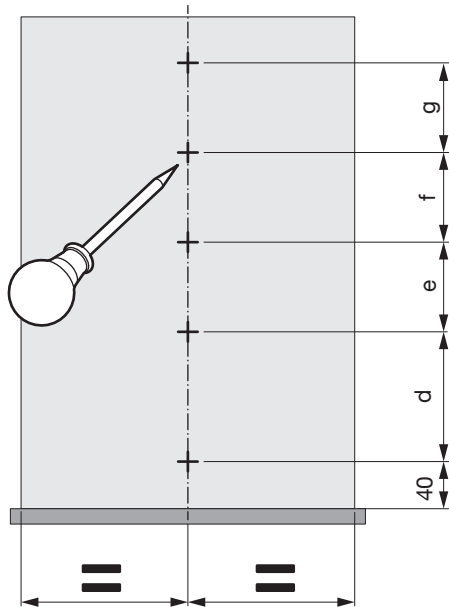
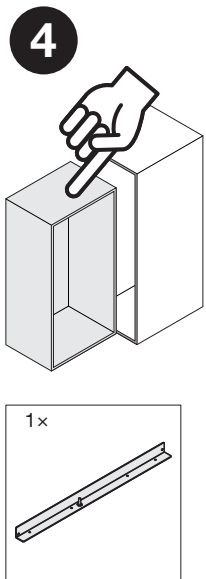
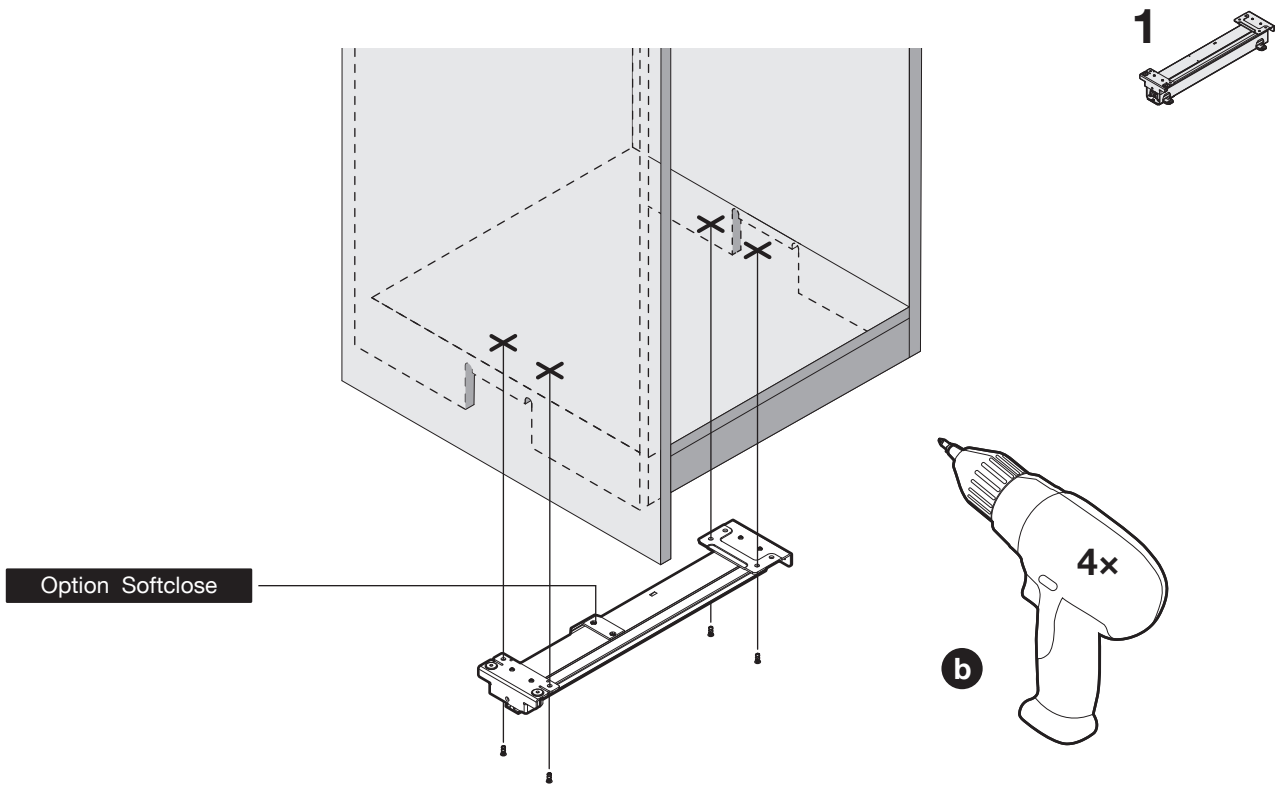

Typ/Type	d	e	f	g
380	150	50	100	-
430		100	100	
480		150	100	
530		200	100	
580	200	100	150	100
630		150	150	
680		200	150	
780	200	200	200	100
880		300	200	
980		400	200	
1080		500	200	

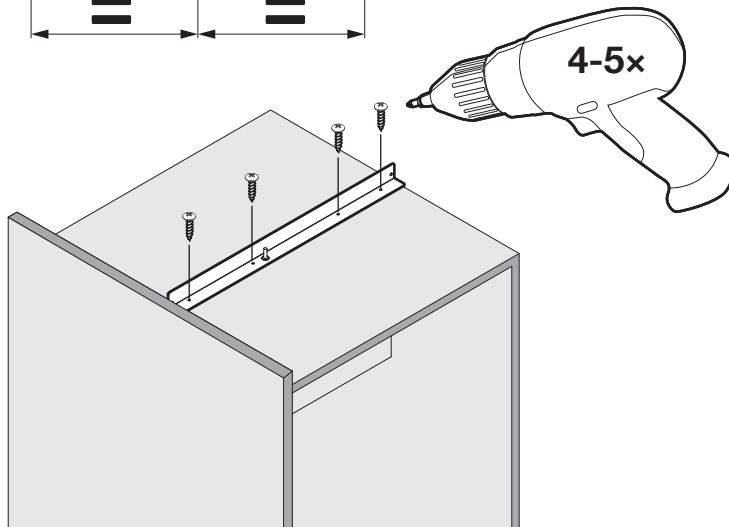
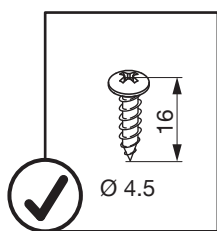

5

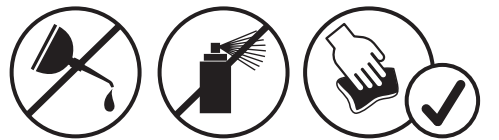
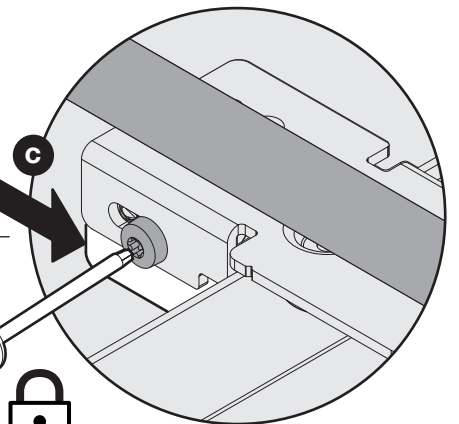
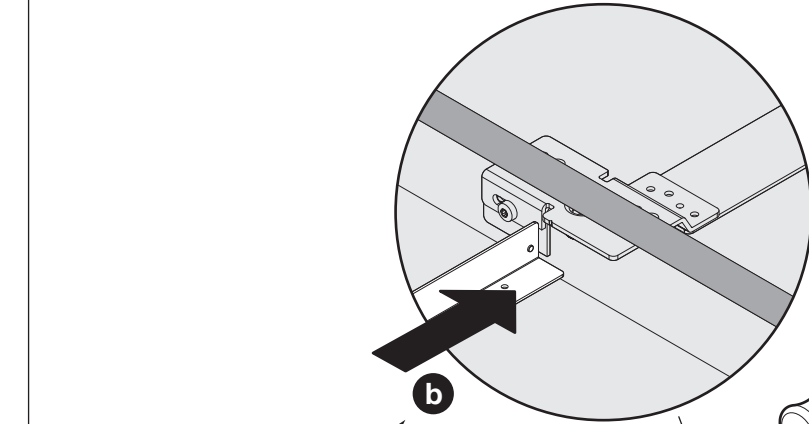
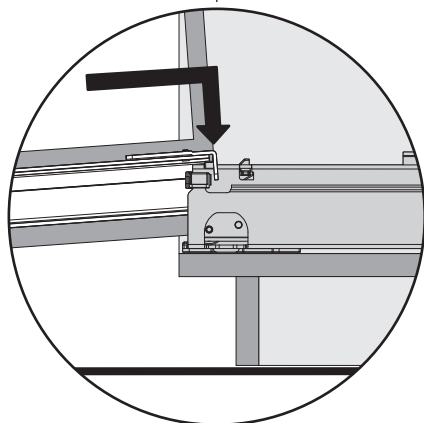
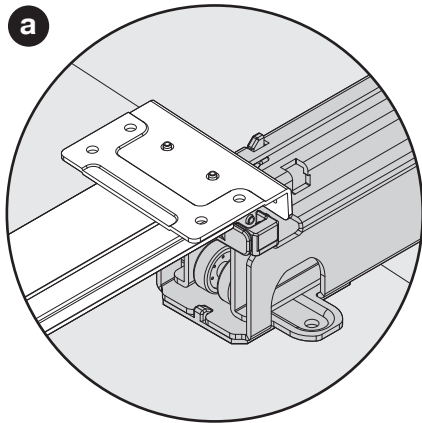
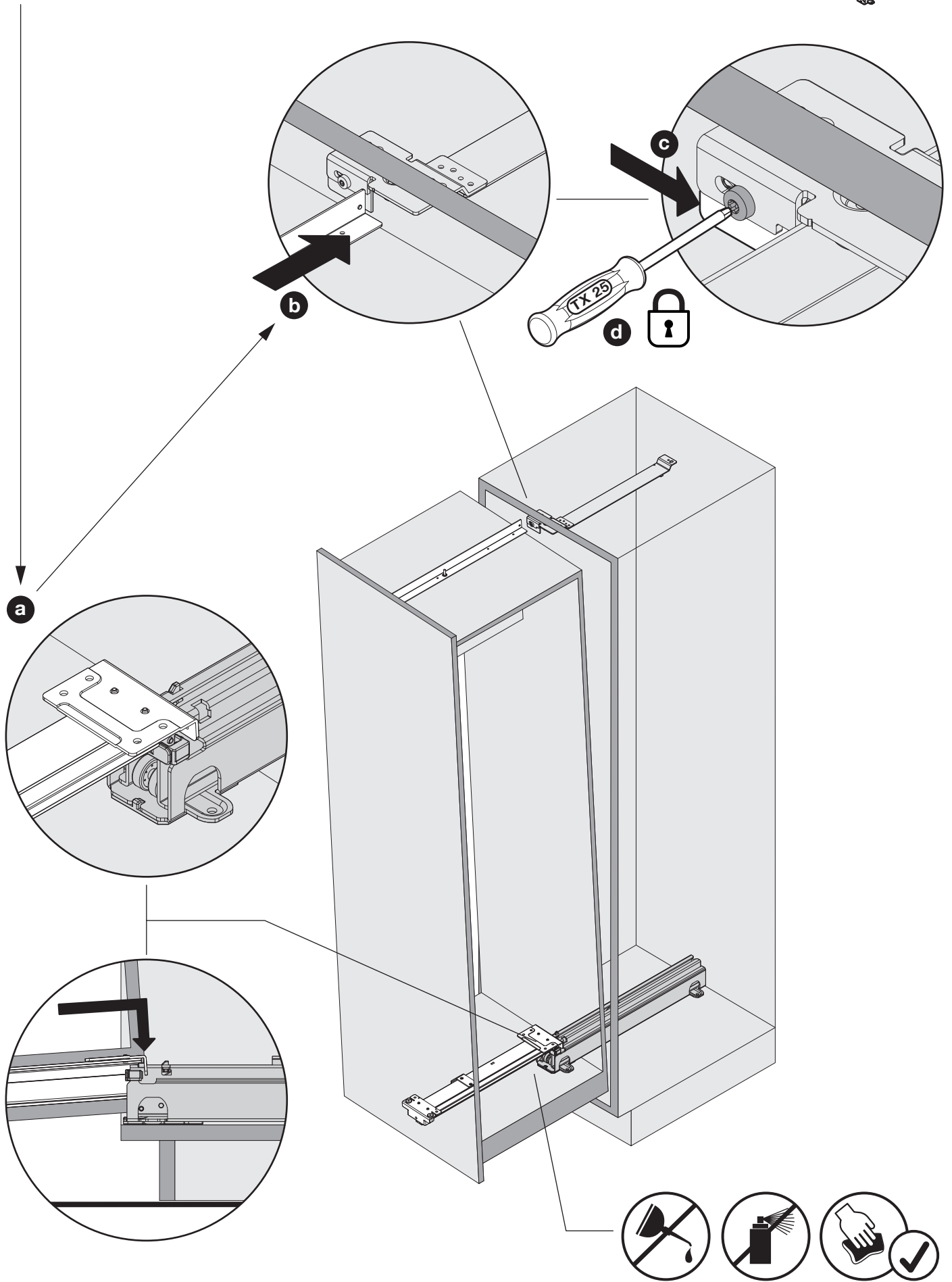
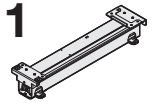

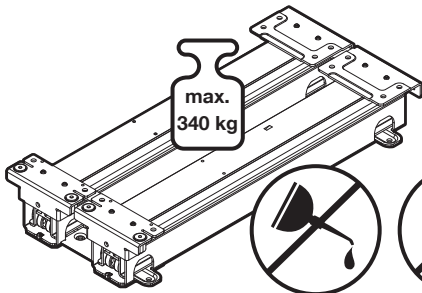
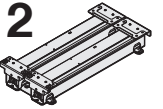

1x

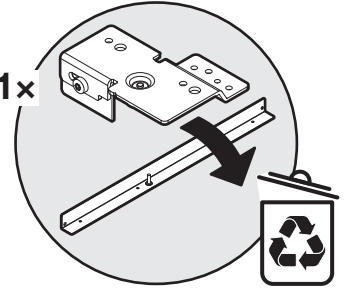

min. 15

40

min. LH x 0.15

max. 2200



Rückwand- und Frontausschnitt
Découpe du panneau arrière et de la façade
Back wall and front cut-out

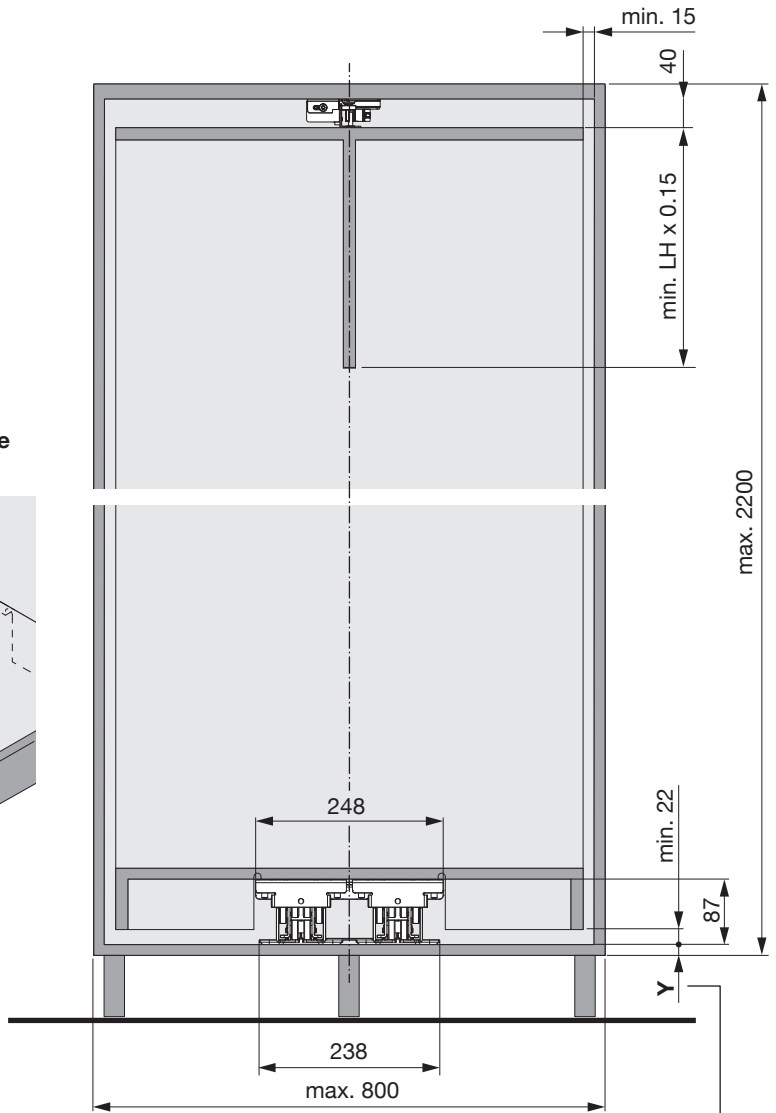
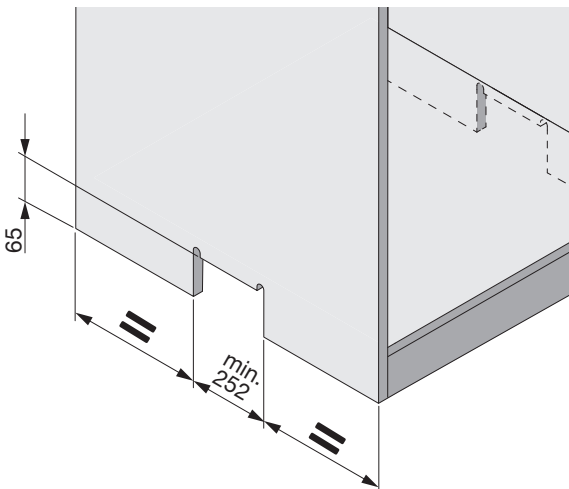

Version A (Standard)
Y = 16 mm

2x 2x 2x 8x 6x

Version B
Y = 16-30
Durchgehend verschraubt
Vissé traversante
Bolted through

4x 4x 4x 12x 2x 6x

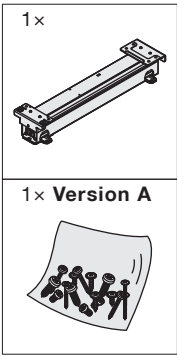
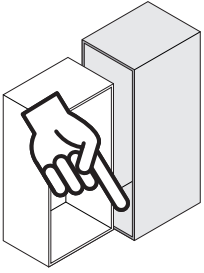
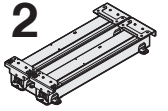
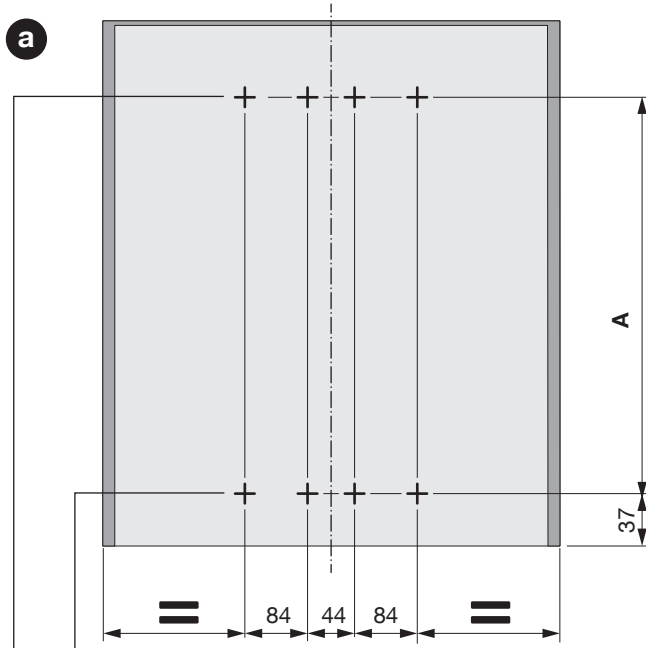

1**2****a**

Typ/Type	A
380	300
430	350
480	400
530	450
580	500
630	550
680	600
780	700
880	800
980	900
1080	1000

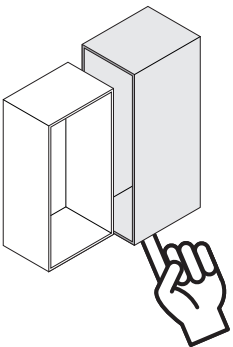
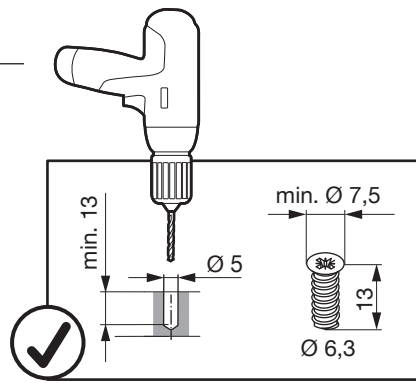
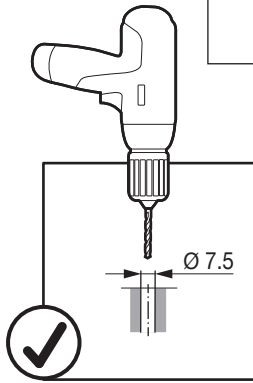
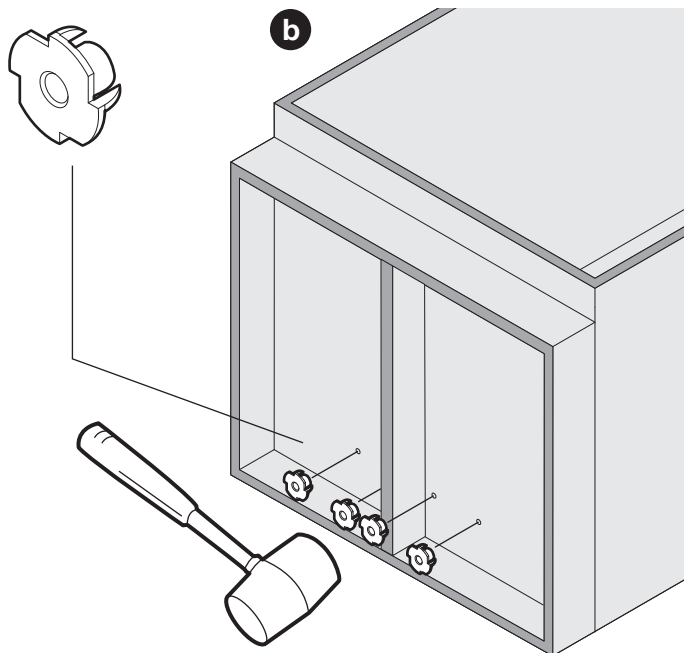
**b**

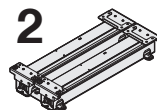

Option Softclose

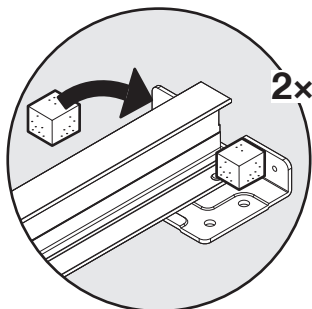
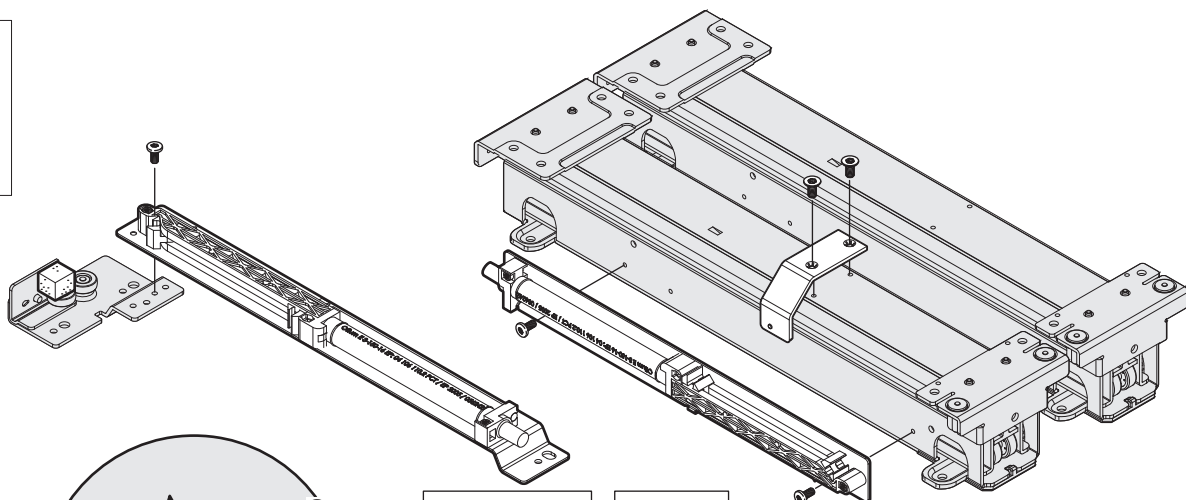
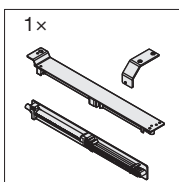

Typ/Type
480, 530, 580,
630, 780
880, 980, 1080

Typ/Type
430

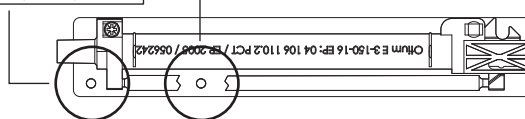

Option



100.1380.xx

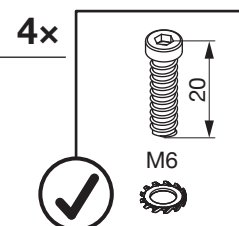
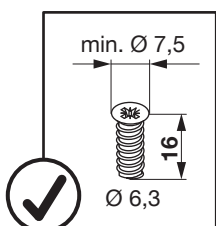
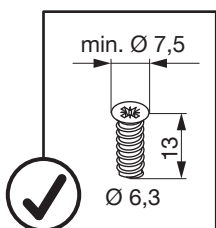
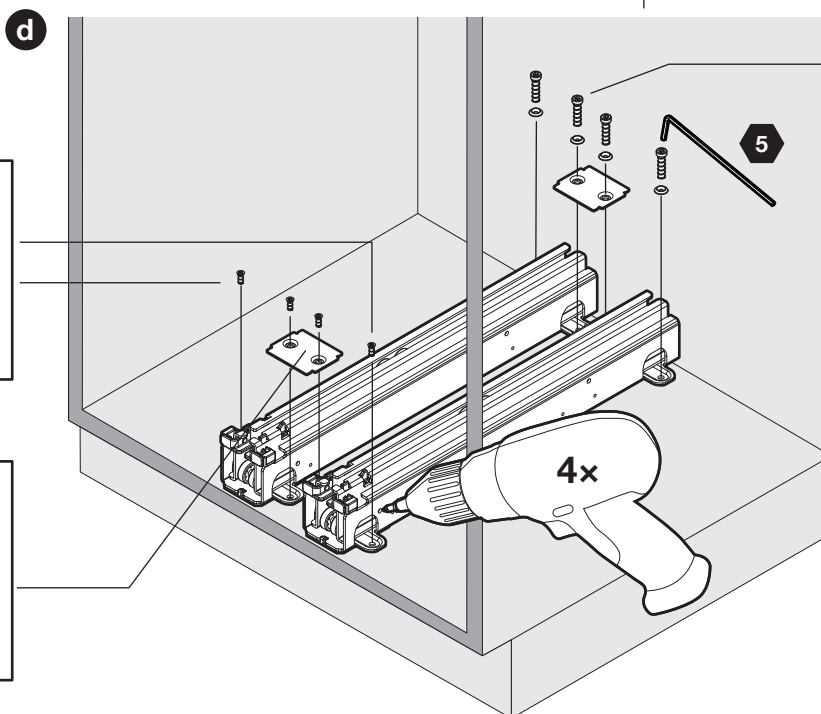
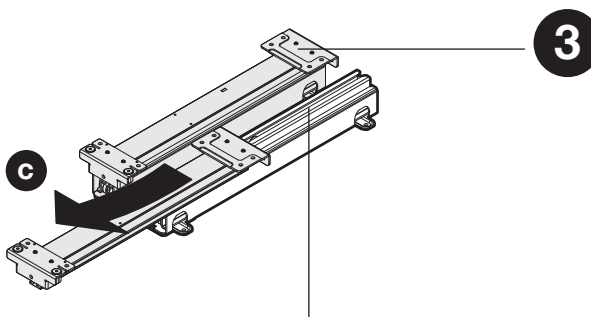

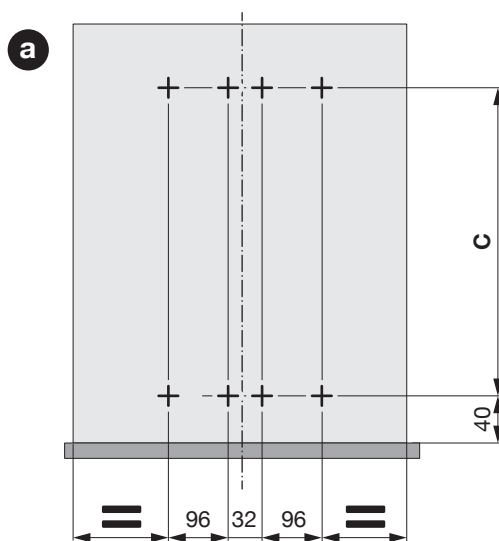
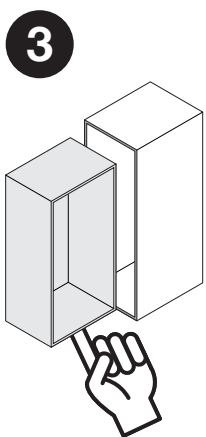
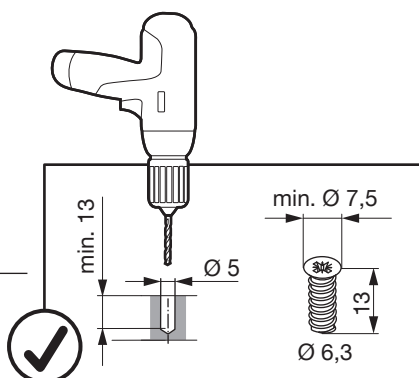
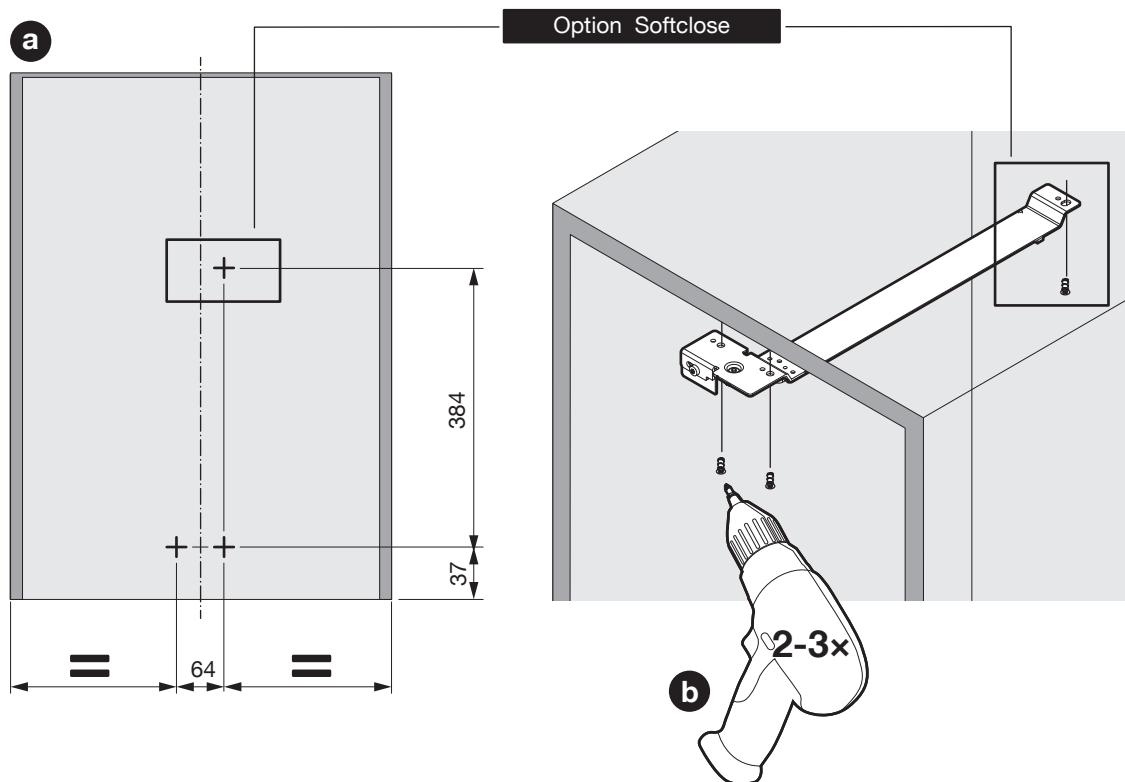
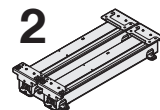
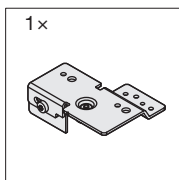
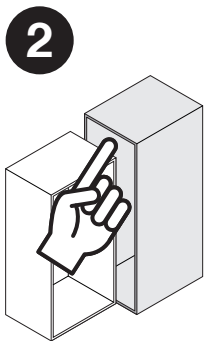

Typ/Type	C
380	280
430	330
480	380
530	430
580	480
630	530
680	580
780	680
880	780
980	880
1080	980

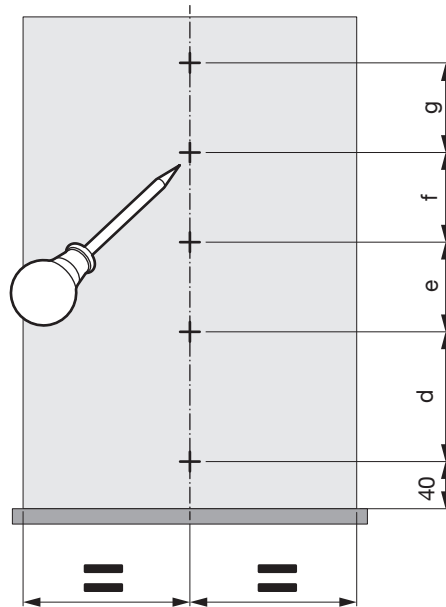
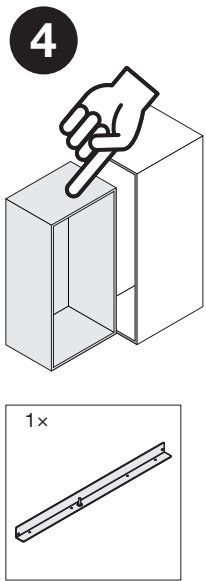
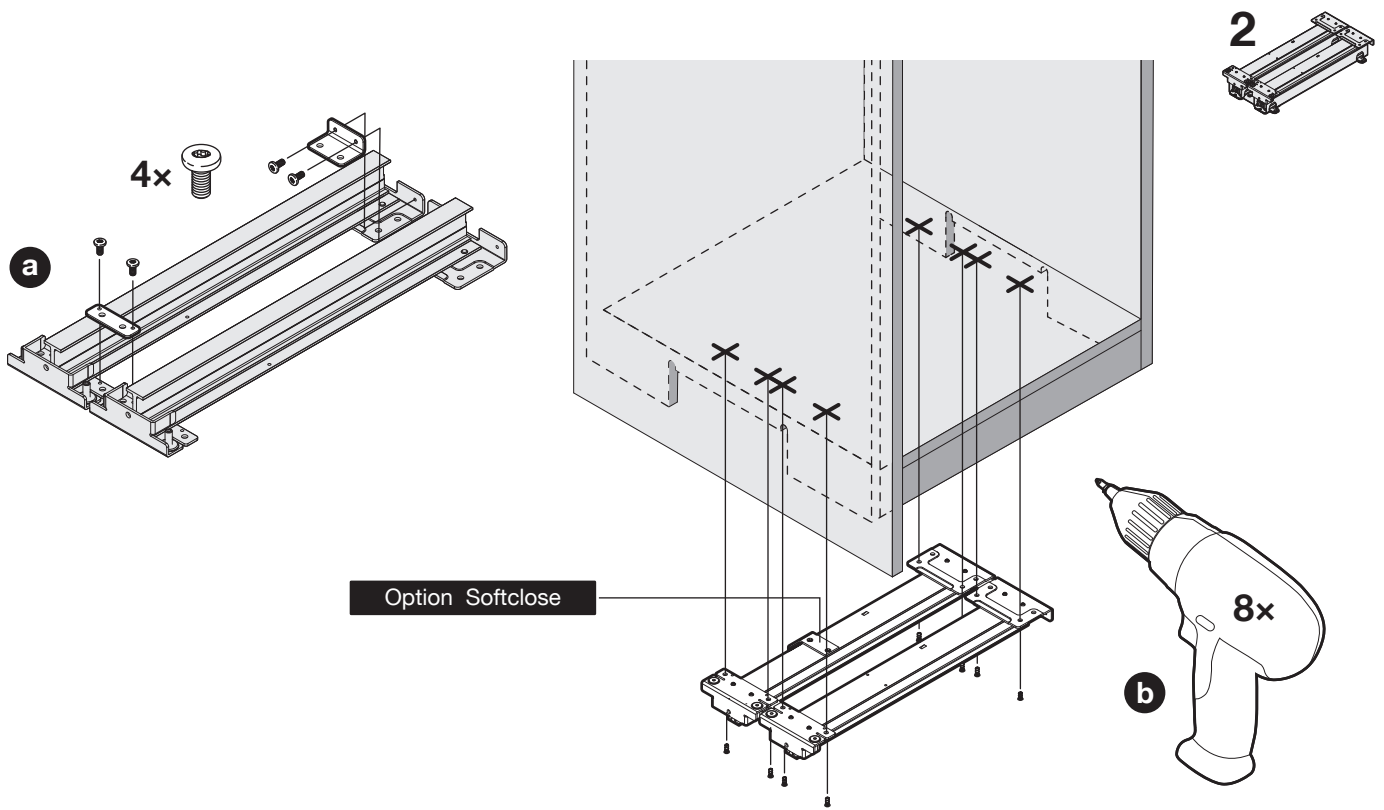

Typ/Type	d	e	f	g
380	150	50	100	-
430		100	100	
480		150	100	
530		200	100	
580	200	100	150	100
630		150	150	
680		200	150	
780	200	200	200	100
880		300	200	
980		400	200	
1080		500	200	

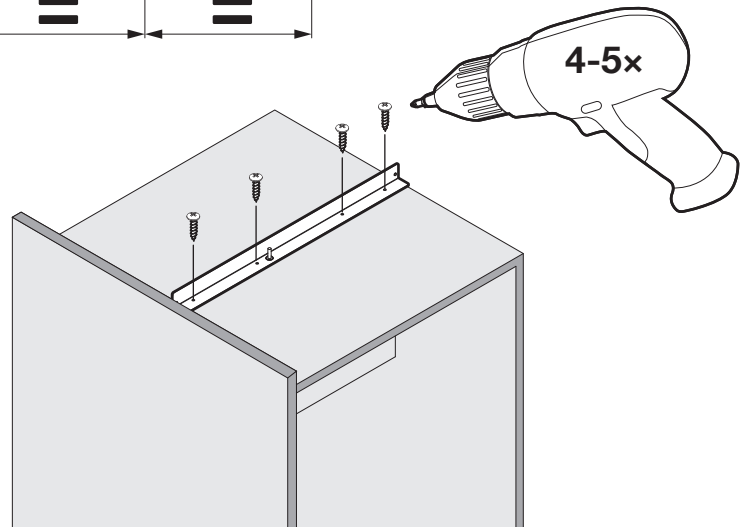
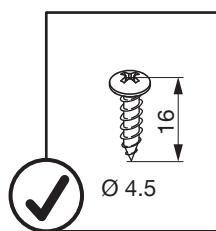

5

2

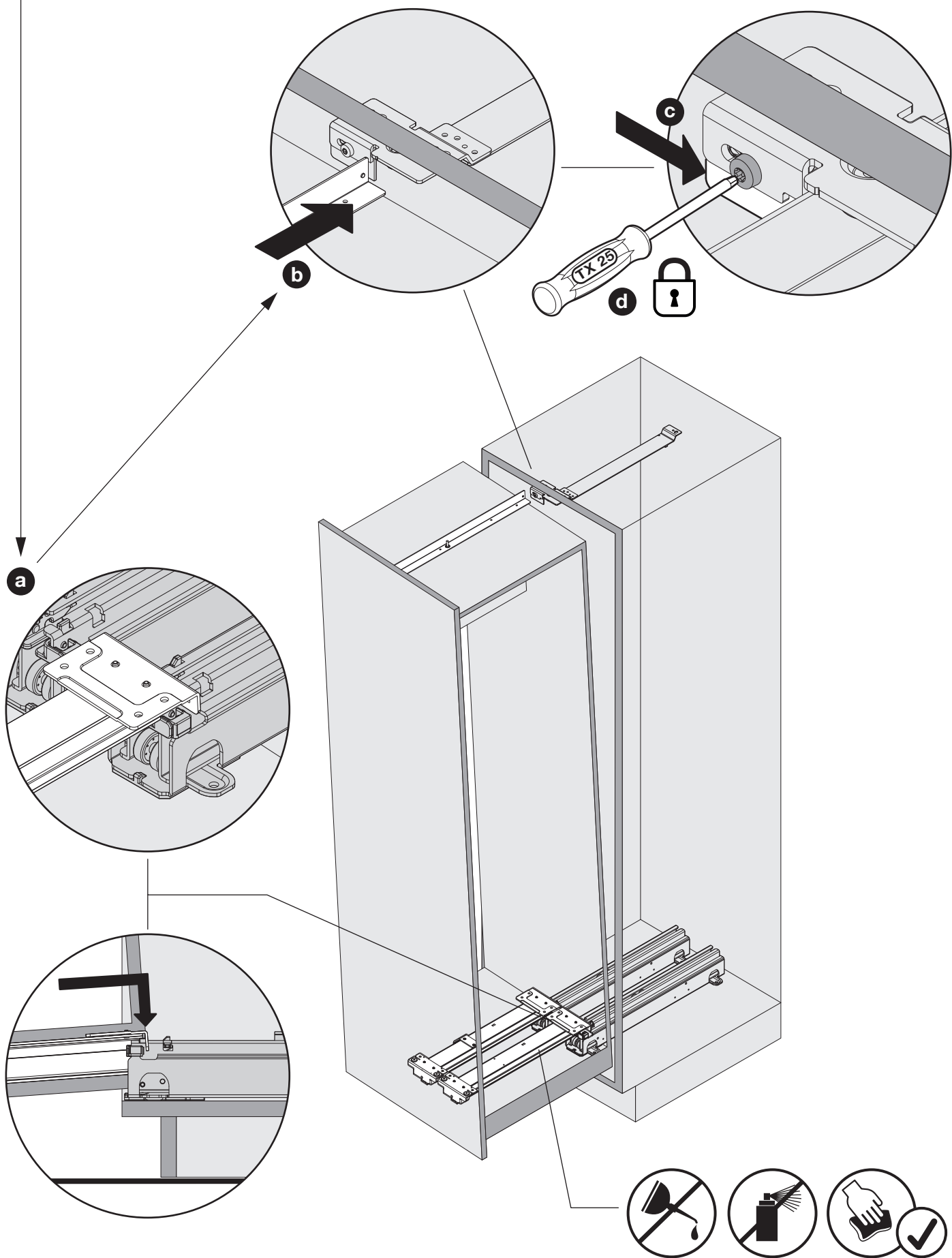

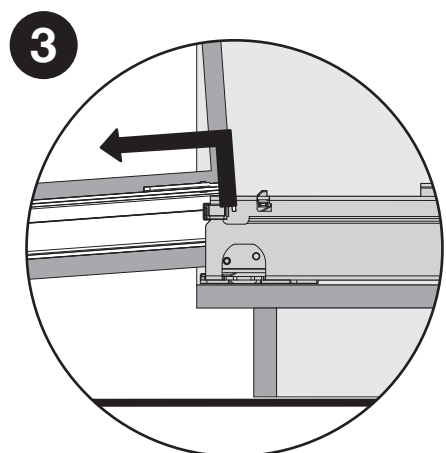
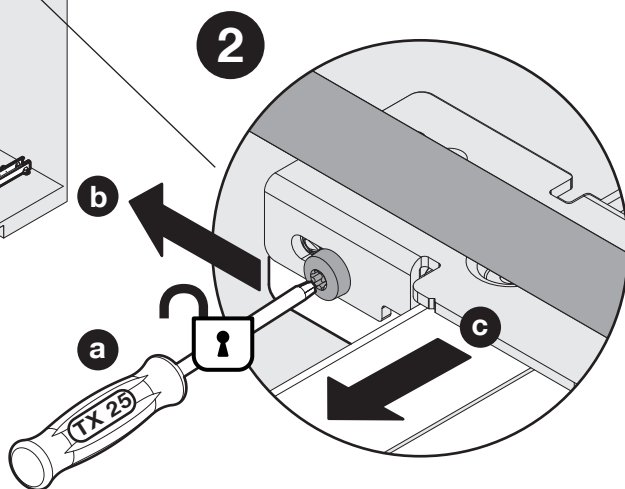
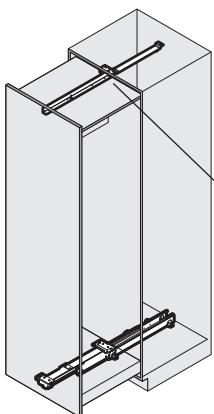
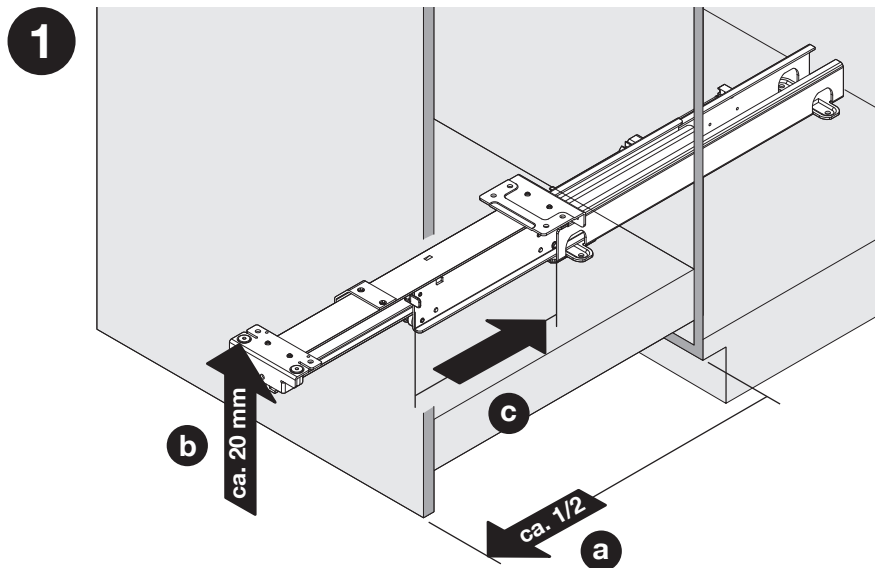
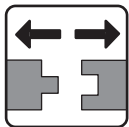
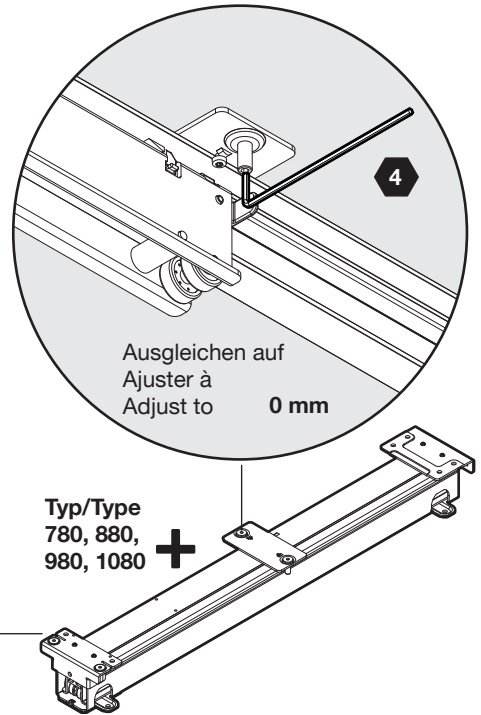
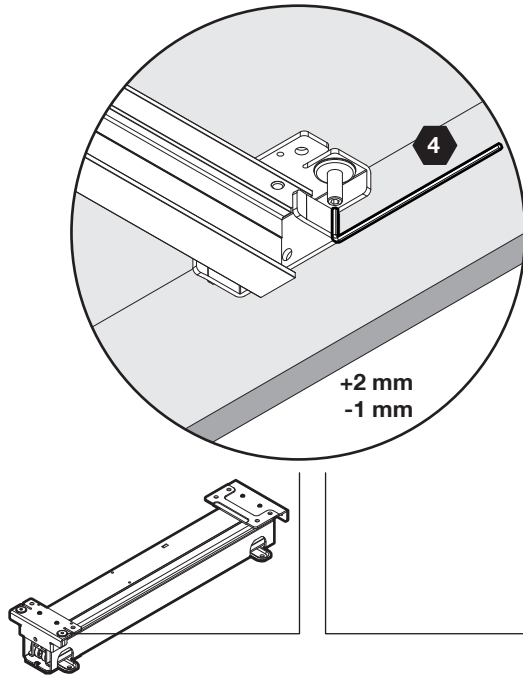
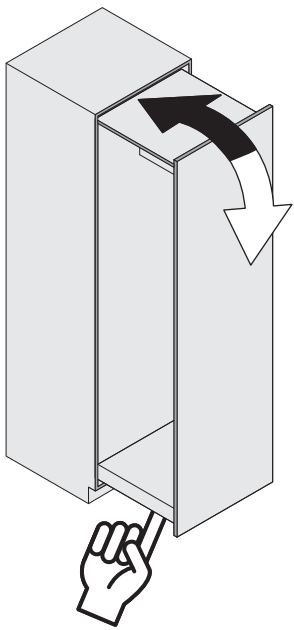



Version B

Y= 16-30

Durchgehend verschraubt

Vissé traversante

Bolted through

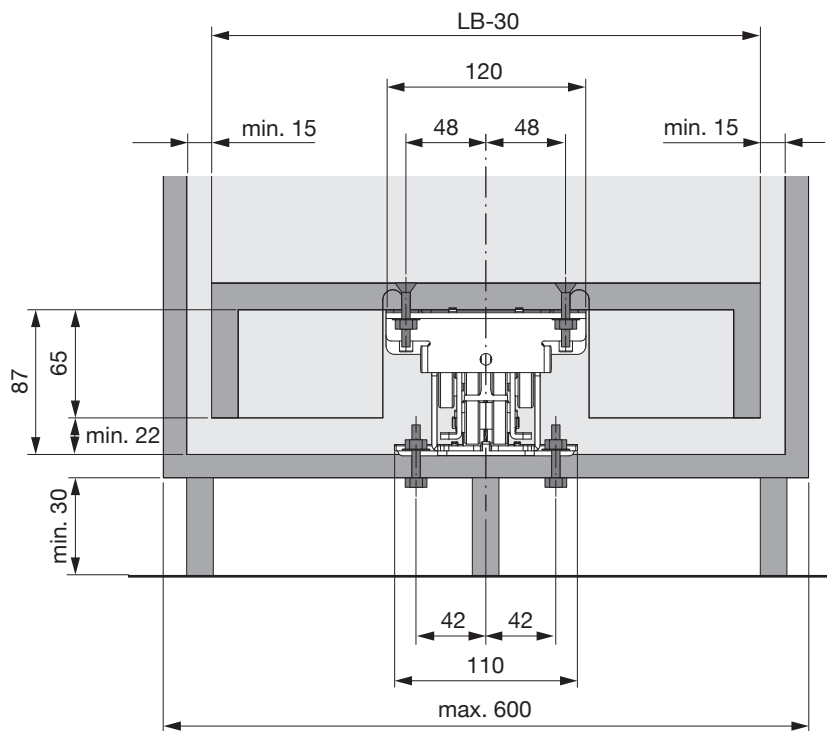
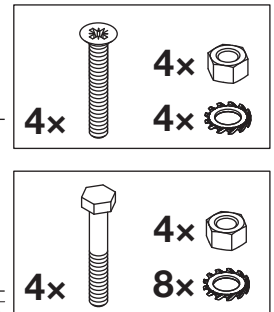
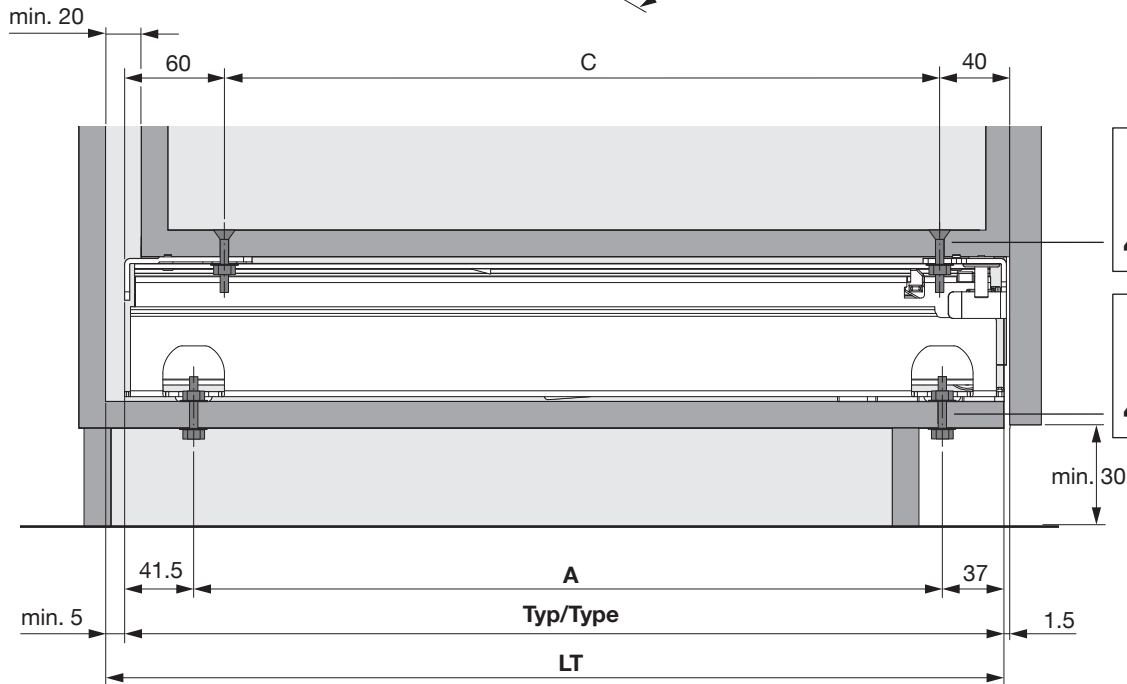
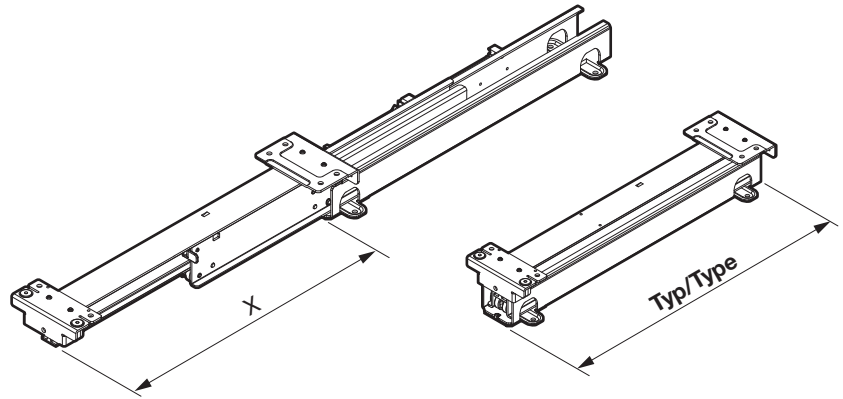

Typ Type	LT	X	A	C	 100.1379.xx
380	385	352	300	280	—
430	435	402	350	330	
480	485	452	400	380	
530	535	502	450	430	
580	585	552	500	480	
630	635	602	550	530	
680	685	652	600	580	✓
780	785	752	700	680	
880	885	852	800	780	
980	985	952	900	880	
1080	1085	1052	1000	980	